

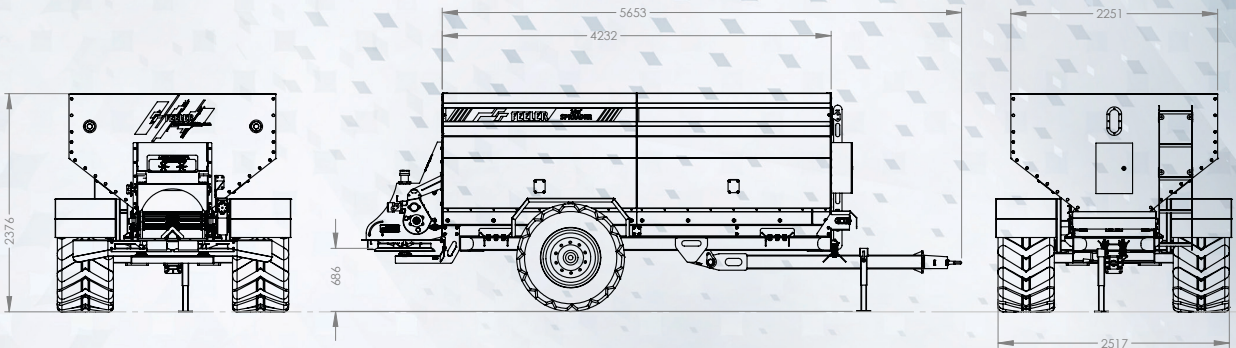

# FERTILIZER

## SPREADER

10M<sup>3</sup>



- \* **3CR12 BIN CONSTRUCTION**
- \* **INTEGRATED STEEL GRIT**
- \* **ADDITIONAL BEATERS TO BREAK DOWN LARGER ORGANIC MATERIAL**
- \* **740MM CHAIN CONVEYOR**
- \* **ABLE TO SPREAD FERTILIZER, GYPSUM AND LIME**
- \* **POWERFUL 50CC SPINNER MOTORS**

Total Width	2517mm
Total length including drawbar	5653mm
Total height	2376mm
Weight	2850kg
Tyre Size	600/50R22.5
Capacity cube	10 cube
Power Required	135kw
Oil flow required	110 l / min
Hydraulic gearbox drive	22:01

Office Contact Details:

**011 979 0131**

[info@feelerafrica.co.za](mailto:info@feelerafrica.co.za)

38 Rokewood Street, Pomona  
Kempton Park, 1619